

PUMP PARTS LIST

ITEM	QTY	PART NUMBER	DESCRIPTION	MATERIAL
1	1	BODY		Iron, Cast
2	2	LOWER BUSH		Brass, Soft Yellow
3	1	SHAFT 1		Steel, Alloy
4	1	SHAFT 2		Steel, Alloy
5	1	ISO 2491 - A 6 x 4 x 20	Thin parallel keys	Steel, Mild
6	1	ISO 2491 - A 5 x 3 x 20	Thin parallel keys	Steel, Mild
7	1	Spur Gear1		Steel
8	1	Spur Gear2		Steel
9	1	UPPER BUSH1		Brass, Soft Yellow
10	1	UPPER BUSH2		Brass, Soft Yellow
11	1	BUSH SEAL		Rubber
12	1	CAP SEAL		Rubber
13	1	CAP		Steel
14	14	DIN 128 - A5	Spring Washer	Steel, Mild
15	14	ISO 4762 - M5 x 20	Hexagon Socket Head Cap Screw	Stainless Steel, 440C
16	1	JIS B 1538 - EN 14 14x35x8	Self-Aligning Ball Bearing	Steel, Mild
17	1	BEARING CAP		Steel
18	2	DIN 128 - A3	Spring Washer	Steel, Mild
19	2	ISO 4762 - M3 x 12	Hexagon Socket Head Cap Screw	Stainless Steel, 440C

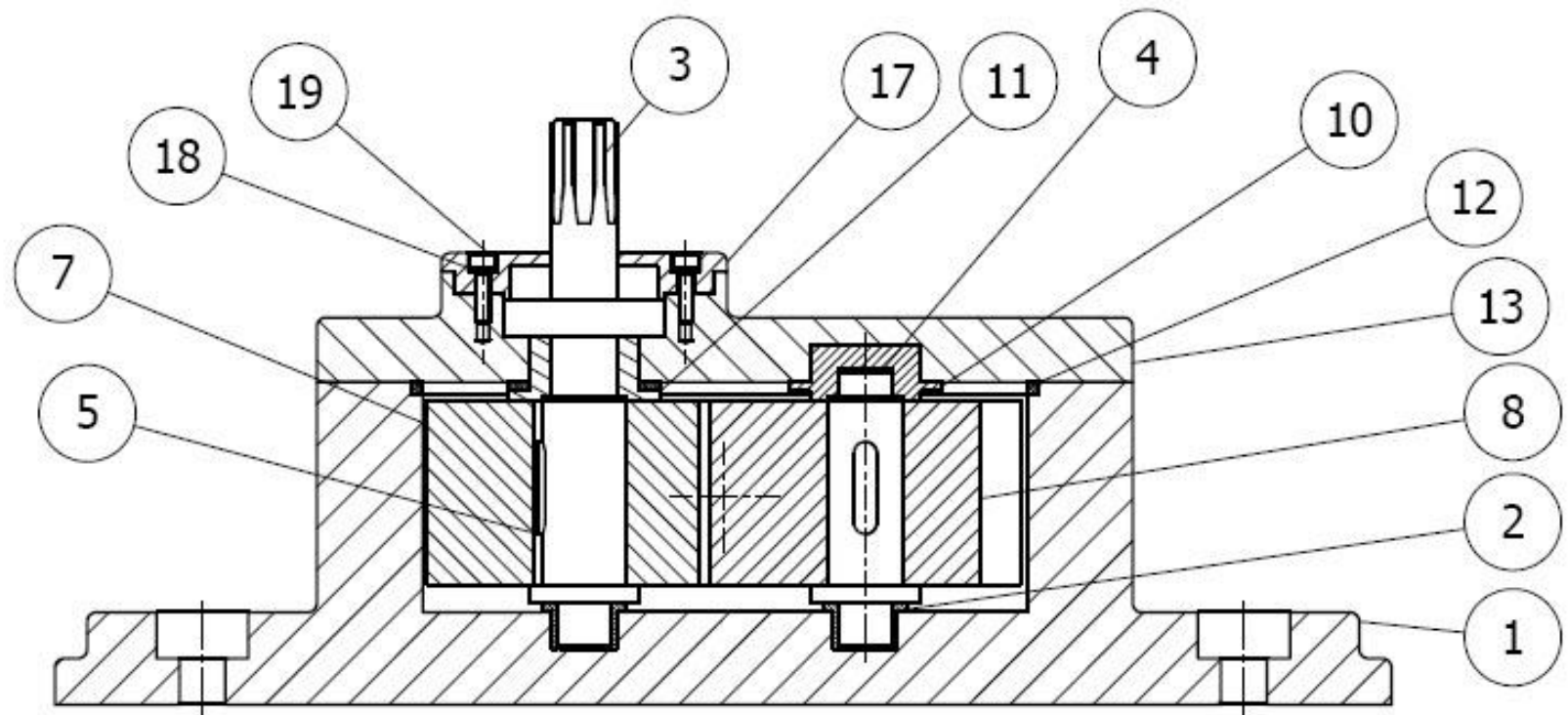

A-A (1:1)

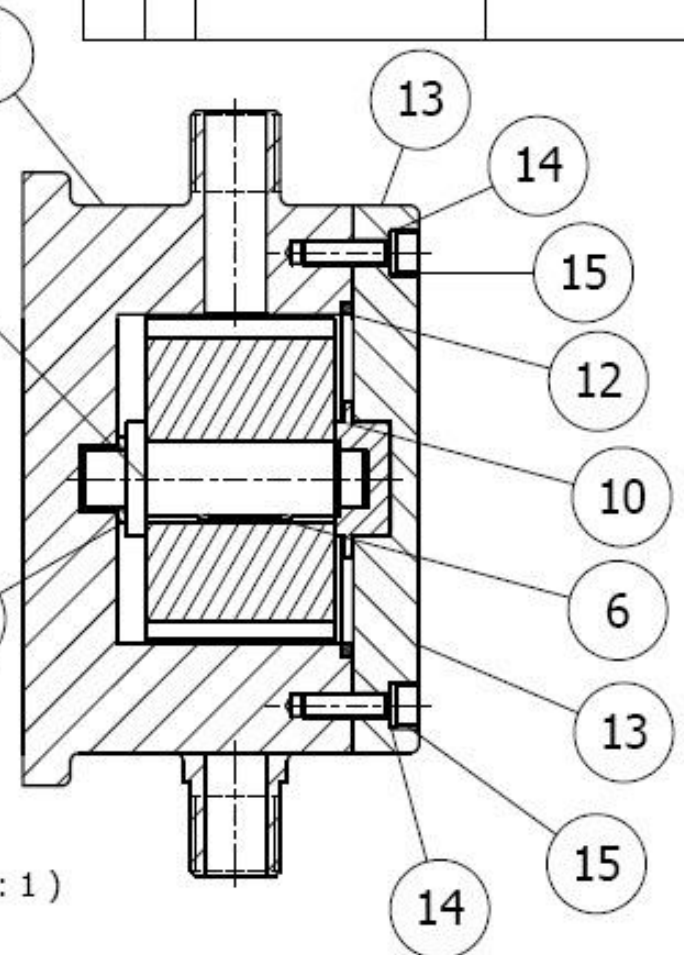
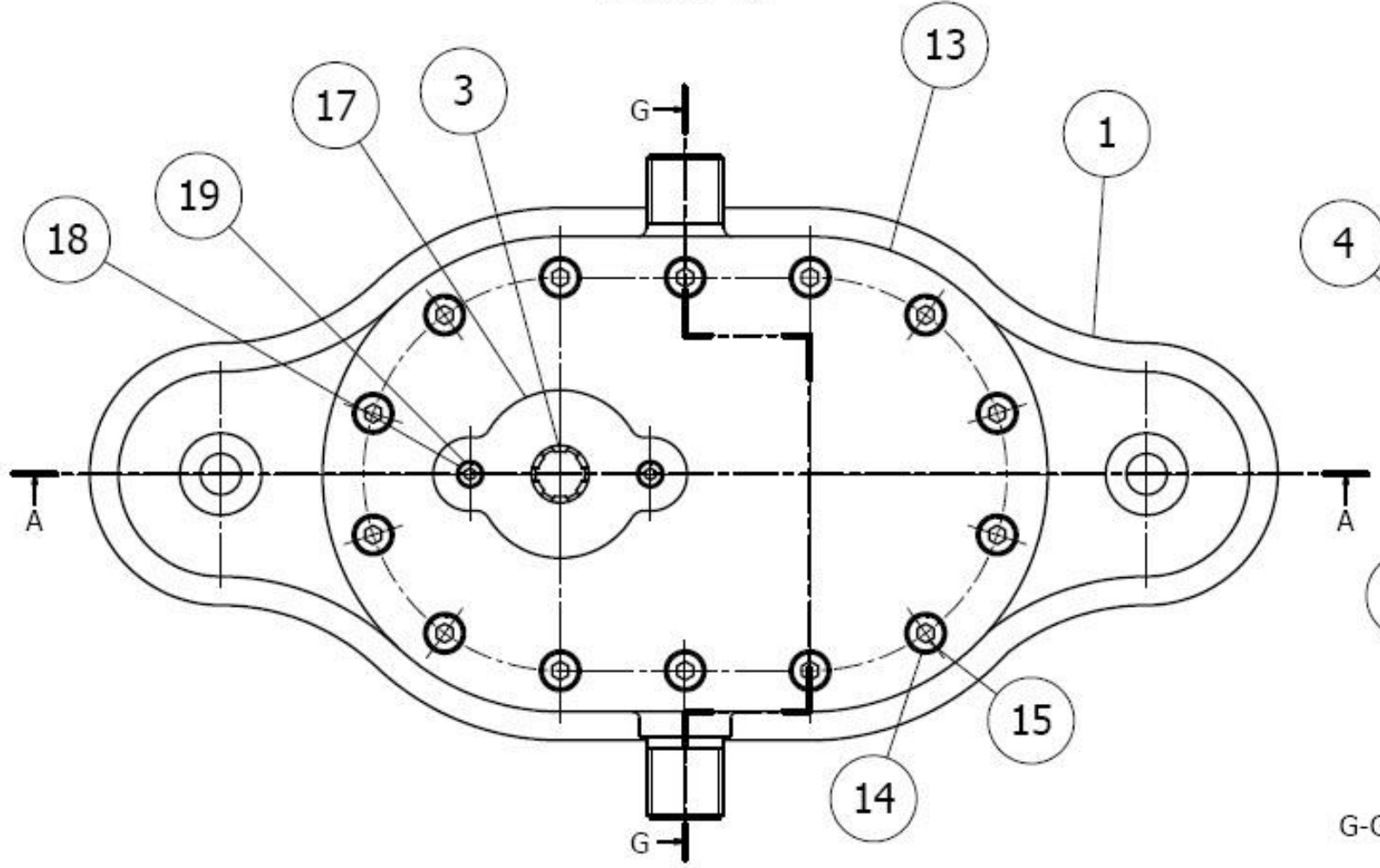

G-G (1:1)

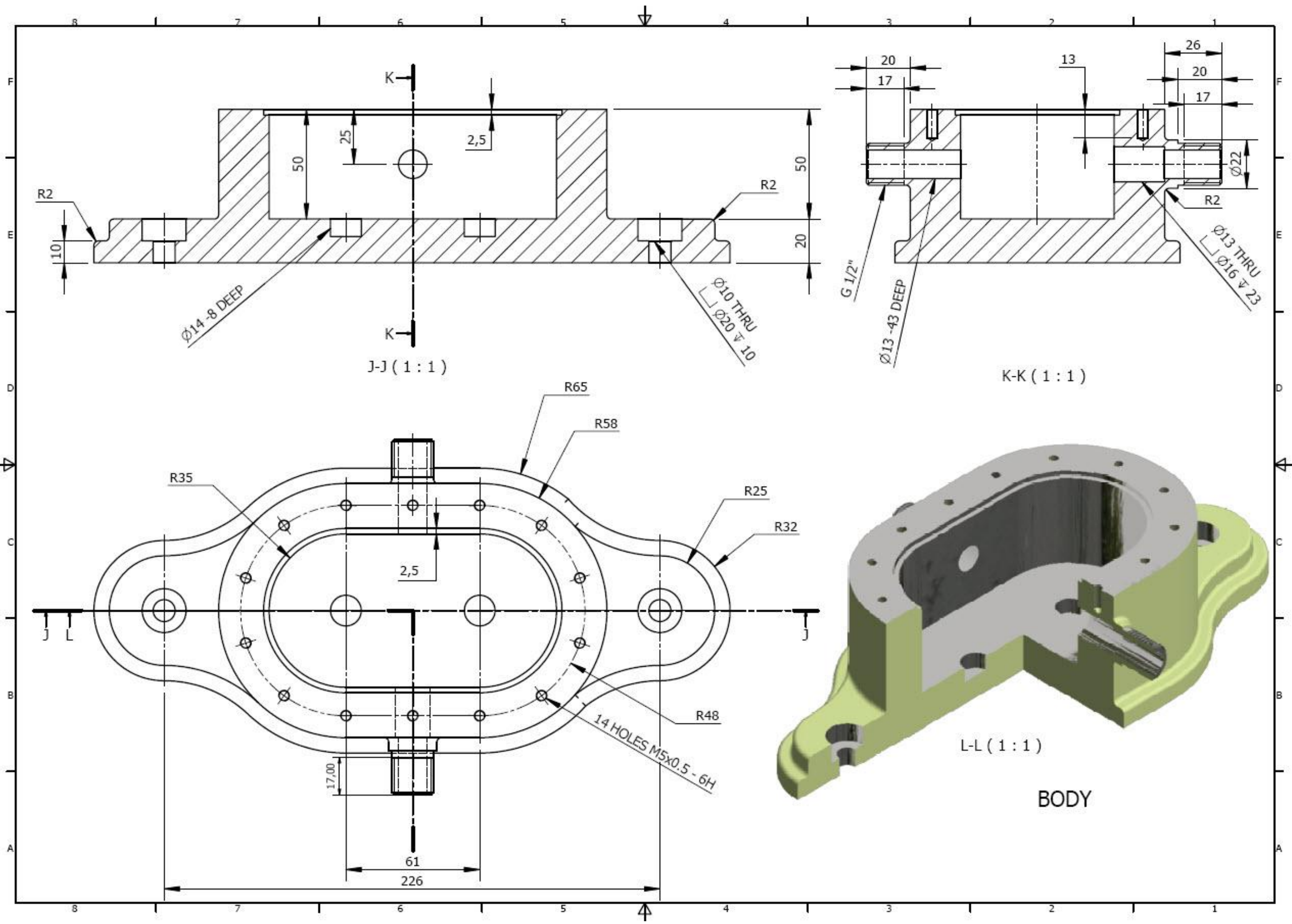

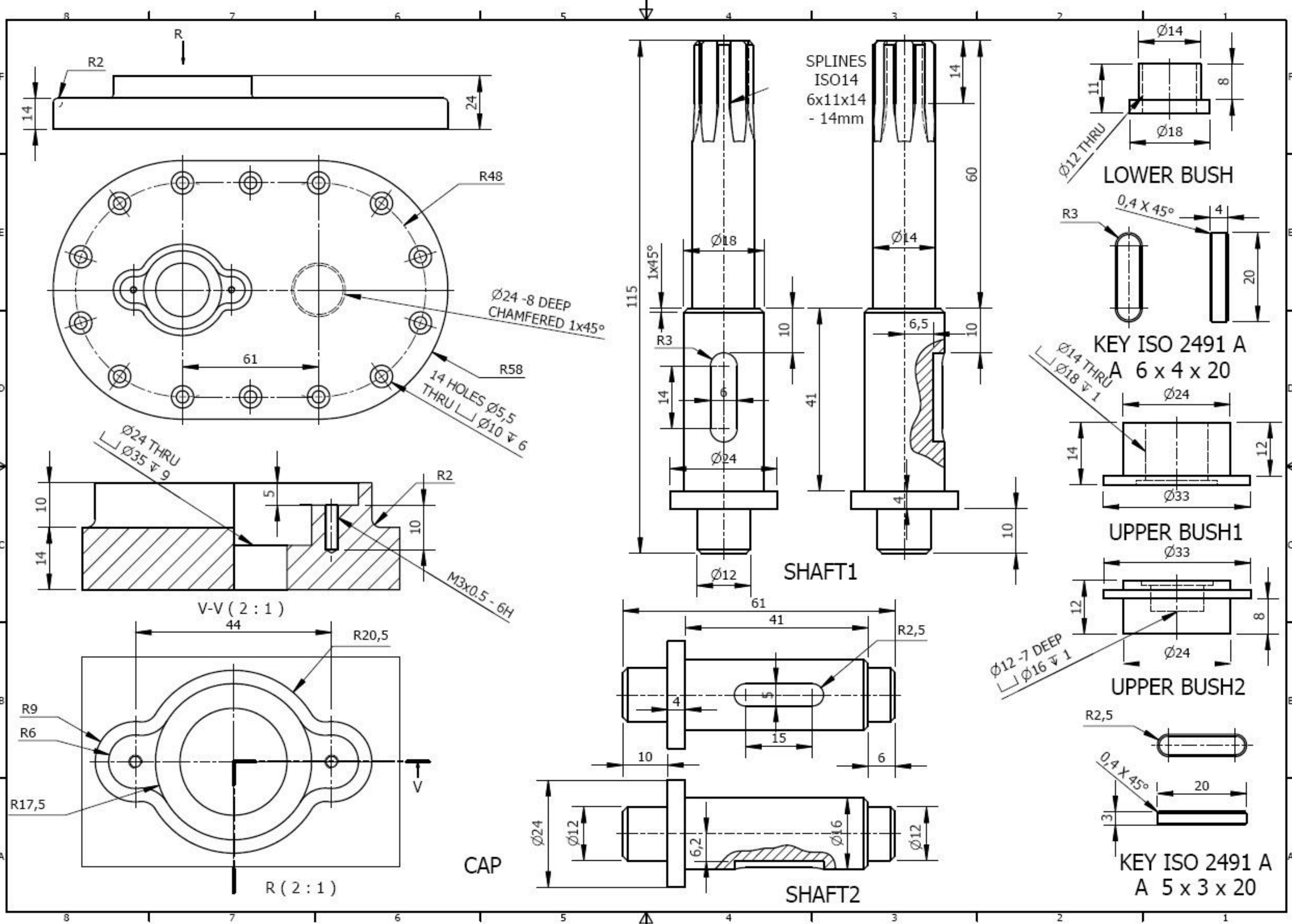

SPUR GEARS
 RATIO = 1
 MODULE = 4
 PRESURE ANGLE = 20°
 CENTER DISTANCE = 61mm
 NUMBER OF TEETH = 15 mm
 FACE WIDTH = 40 mm
 POWER = 3 kW
 SPEED = 5000 rpm

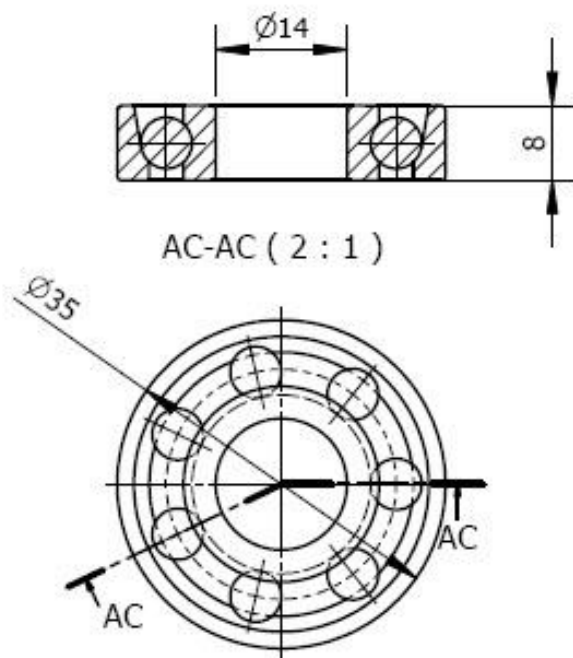
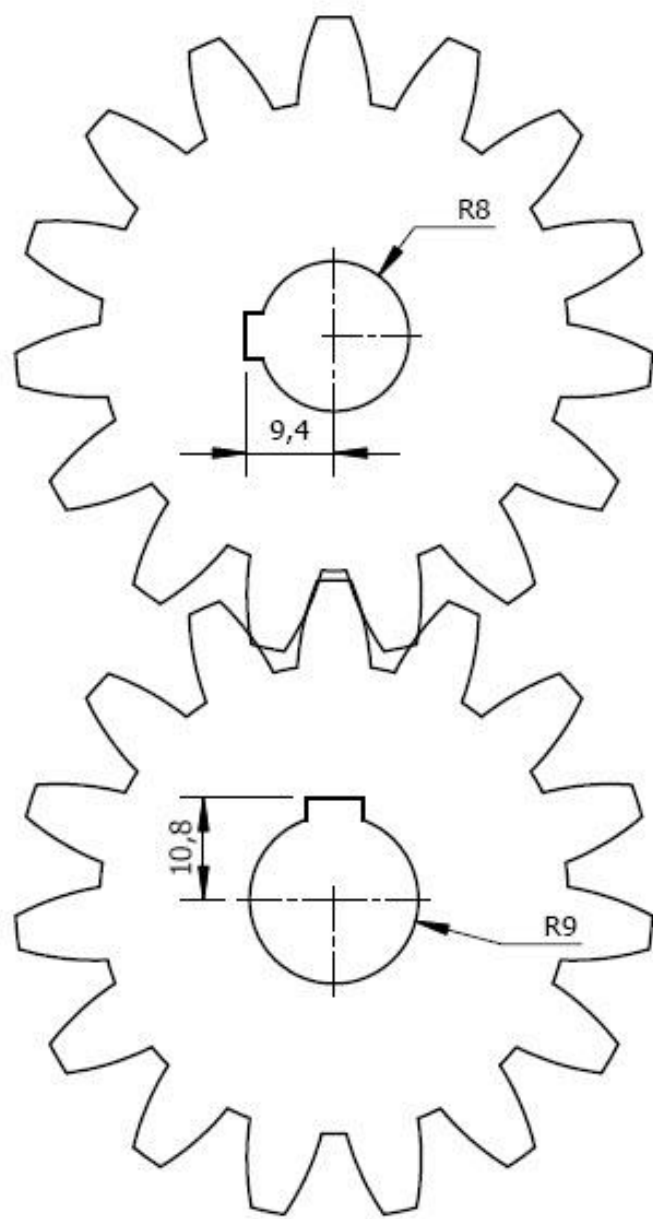

BALL BEARING JIS B
 1538 EN 14 14x35x8

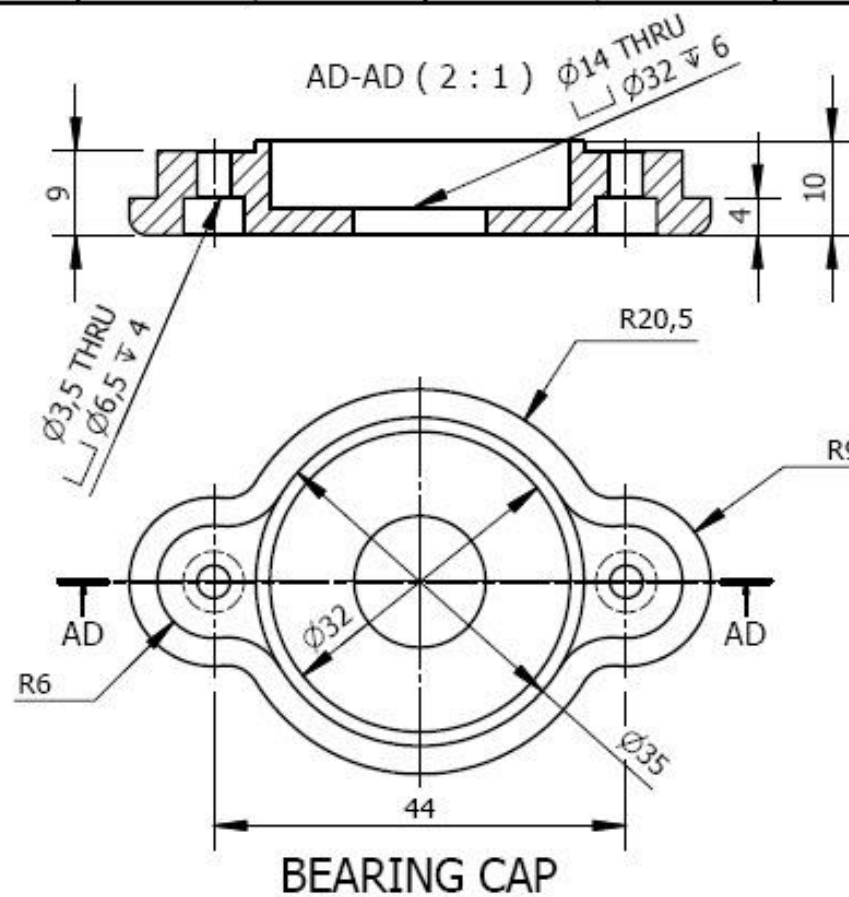

BEARING CAP

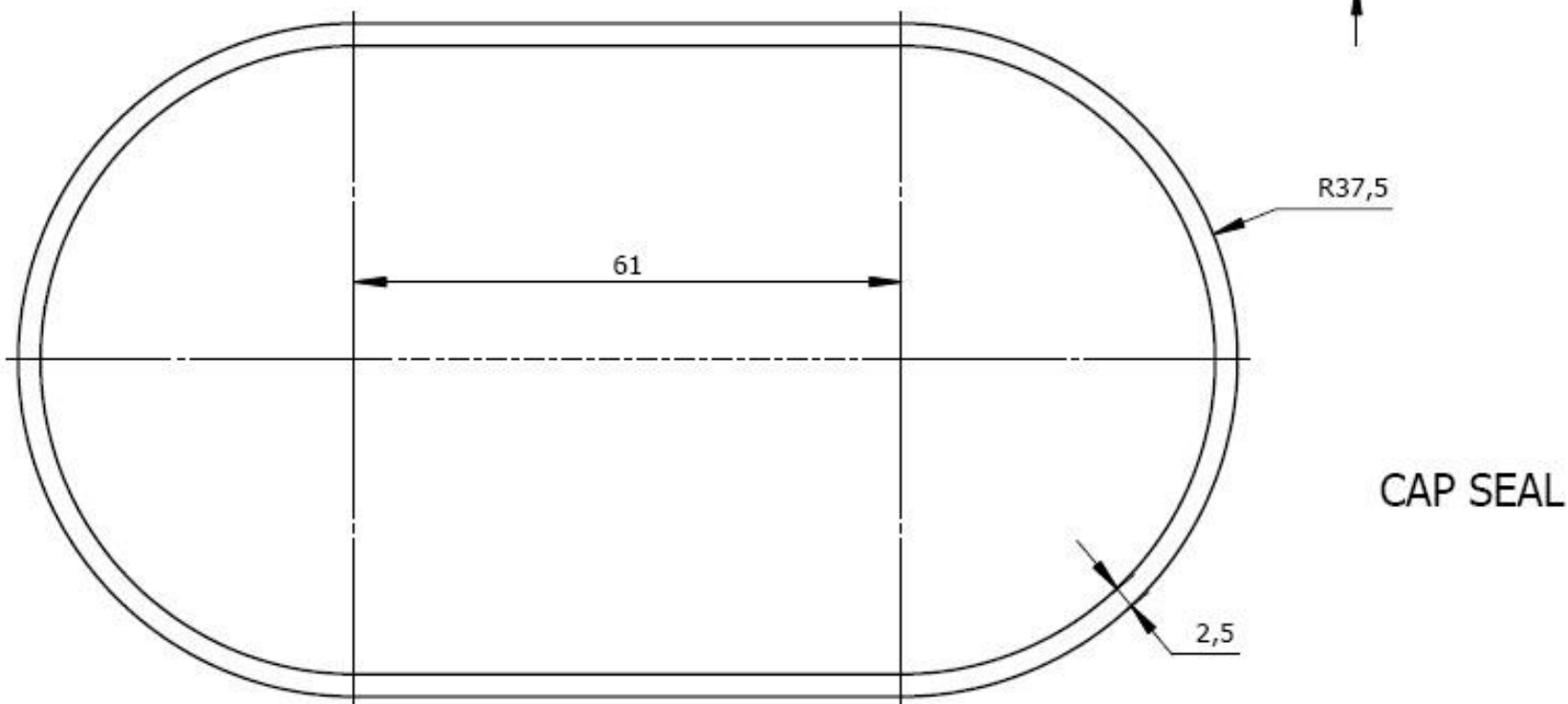
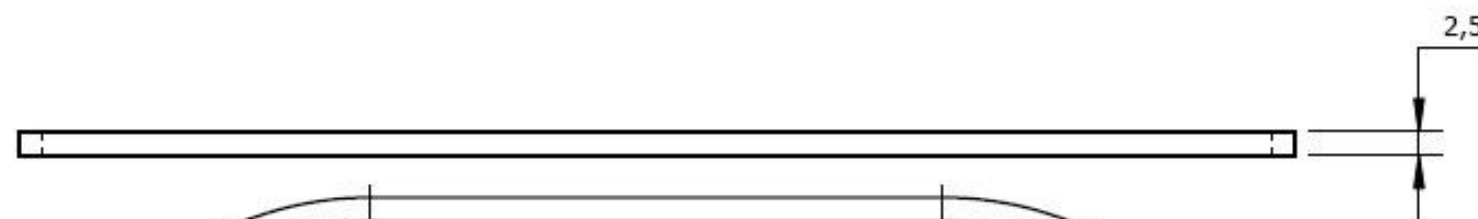

CAP SEAL